

# The Power of RED



## OPERATING INSTRUCTIONS AND PARTS MANUAL

CLEFORM TOOL CO. Manufacturer of the Gilson Mixers  
4343 Easton Road  
St. Joseph, MO 64503

MODEL # 59000D

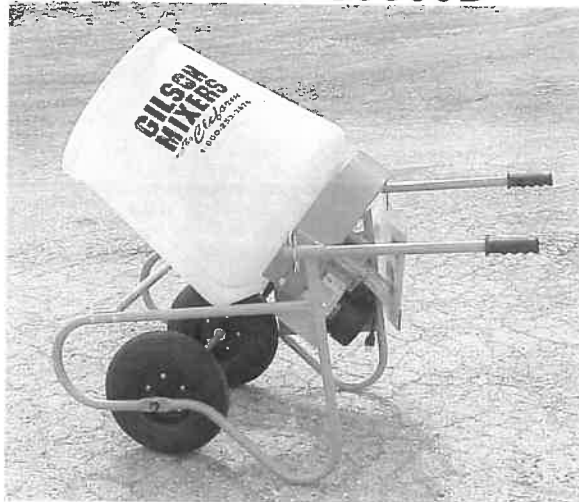

**IMPORTANT—READ THIS MANUAL BEFORE ASSEMBLING OR OPERATING**

After referring to the operation manual, if you still require assistance,  
please contact our customer service department .

PH: (800) 253-3676 FAX: (888) 253-3676 sales@cleform.com www.gilsonmixer.com

## **GILSON MIXERS # 59000D Portable Wheelbarrow Mixer** 1/2HP Motor, On/Off Switch, and New Drum with In-Mold Blades!

The Gilson Wheelbarrow mixer is great for the do-it-yourselfer for home projects. Allows you to work almost anywhere – The mixer will clear a 30" door and easily fits into an elevator. Quiet 115-volt motor allows you to work indoors without emissions.

Cleform's exclusive in-mold helix drum gives a better homogenous mix. The lifting action picks material up from the base of the drum.

Used in the mixing of concrete, plaster, adhesives, overlays, chemicals, seed, and grain – the options are endless.

Mixes 3 ½ Cu. Ft. of cement, mortar mix, or 2 bags of pre-mix concrete.  
High torque ½ HP single phase 115 volt electric motor and "On/Off" Switch  
Strong polyurethane drums will not crack or rust  
Ring gear is enclosed for safe operation  
Lightweight – 125 lbs. – Can ship UPS  
Handles adjust for easy storage  
Clears a 30 inch door opening  
Fast mixing and easy clean up  
Simple drive system  
Quiet Operation  
Easy Assembly

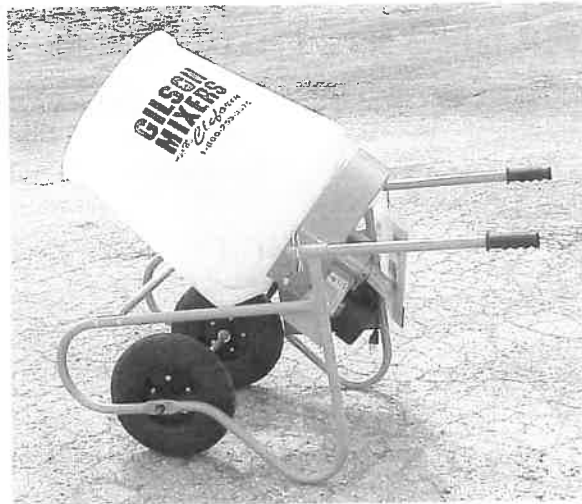

### **Cleform Tool Corp.**

St. Joseph, MO

PH: (800) 253-3676 FAX: (888) 253-3676

EMAIL: [sales@cleform.com](mailto:sales@cleform.com) [www.cleform.com](http://www.cleform.com)

# WHEELBARROW CEMENT MIXER ASSEMBLY GUIDE

## Frame Assembly

Frame Parts Consist Of:

Assemble the tires on the axle.  
Attach the tire and axle to the frames.  
Pre-fix the tire and the frame.  
Assemble the supporting pipe.  
Assemble the drum support frame.  
Fasten all the bolts and nut.

## Motor Assembly

Fix the belt drive pulley on the motor shaft.  
Pre-assemble the motor on the frame.  
Assemble the timing belt driven pulley on the frame.  
Assemble the timing belt on the pulleys.  
Adjust the belt tension and keep it parallel to the pulleys.  
Fasten the motor and belt pulley.  
Fixing the motor cover on the frame.  
Fixing the gear protector cover to the frame.

## Drum Assembly

Familiarize yourself with the drum fixing components.  
Assemble the central paddle and its pad on the drum.  
Assemble the gear wheel on the shaft from the drum bottom.  
Fix the paddle and the pad by bolts.  
Put the washer on the gear shaft.  
Assemble the drum on the frame.  
Fix the shaft positioning sleeve on the gear shaft.  
Assemble the handle on the frame.  
Set the handle fixing spring clip on the handle.  
Wear the plastic handle cover.

## Wheelbarrow Cement Mixer Parts Exploded View

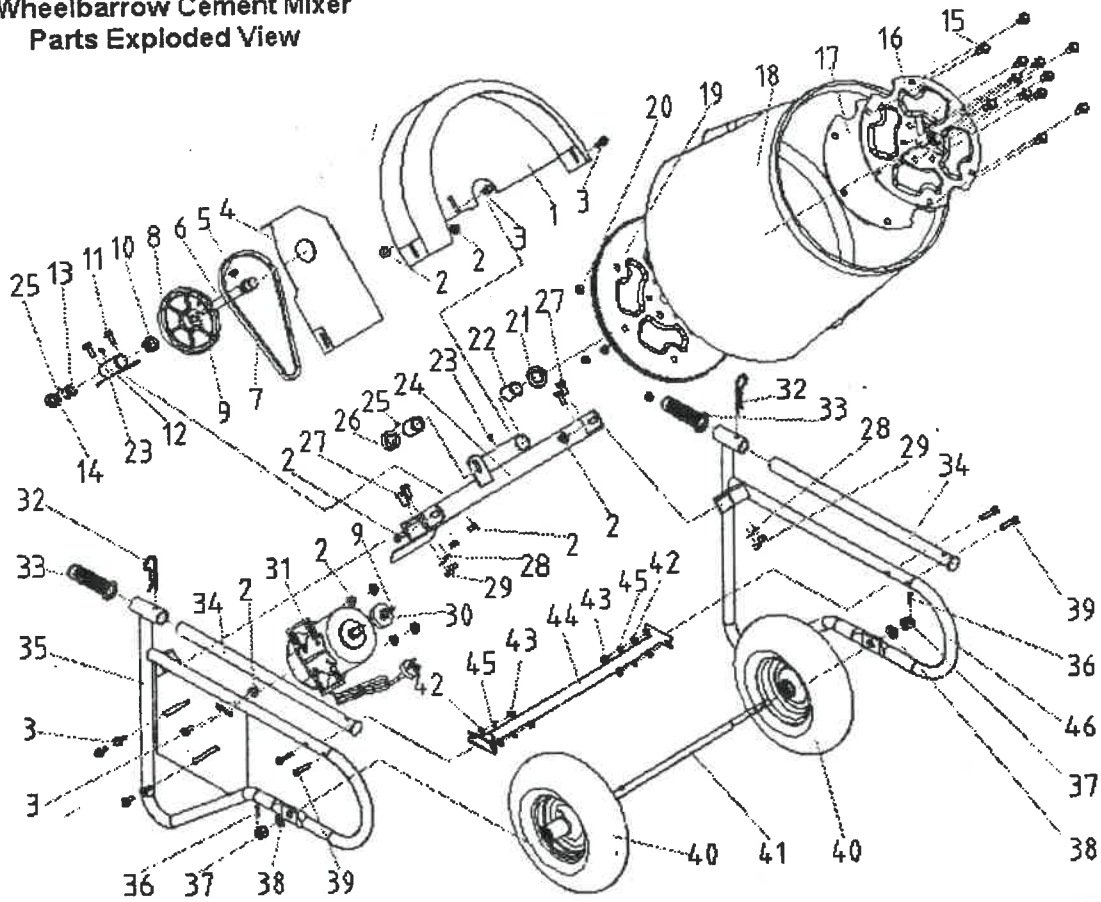

| Part #    | Description                      | Spec.        | Qty. | Part #    | Description                    | Spec.          | Qty. |
|-----------|----------------------------------|--------------|------|-----------|--------------------------------|----------------|------|
| 59000D-1  | Plastic Gear Guard               | ABS          | 1    | 59000D-24 | Drum Support Frame             |                | 1    |
| 59000D-2  | Hex Flange Nut                   | M8           | 10   | 59000D-25 | Hex Socket Screw               | M8 x 8         | 1    |
| 59000D-3  | Hex Flange Bolt                  | M8 x 20      | 8    | 59000D-26 | Gear Shaft Sleeve              | #45 C. Steel   | 1    |
| 59000D-4  | Plastic Belt Guard               | ABS          | 1    | 59000D-27 | Hex Bolt                       | M10 x 25       | 4    |
| 59000D-5  | Set Screw                        | 6 x 20       | 1    | 59000D-28 | Lock Washer                    | D10            | 4    |
| 59000D-6  | Pinion Gear Shaft                | #45 C. Steel | 1    | 59000D-29 | Hex Nut                        | M10            | 4    |
| 59000D-7  | V Belt                           | A680         | 1    | 59000D-30 | Drive Pulley                   | YX041          | 1    |
| 59000D-8  | Driven Belt Pulley               | YX041        | 1    | 59000D-31 | Motor (Model # YCG71)          | 1/2 HP, 4-Pole | 1    |
| 59000D-9  | Set Screw                        | M6 x 8       | 2    | 59000D-32 | Spring Clip                    | 65 MN          | 2    |
| 59000D-10 | Gear Shaft Slide Bearing #       | Nylon 66     | 1    | 59000D-33 | Handle Grips                   | Nylon 66       | 2    |
| 59000D-11 | Hex Flange Bolt                  | M8 x 25      | 2    | 59000D-34 | Handle                         |                | 2    |
| 59000D-12 | Gear Positioning Sleeve Assembly |              | 1    | 59000D-35 | Right Wheelbarrow Frame        |                | 1    |
| 59000D-13 | Gear Shaft Slide Bearing #       | Nylon 66     | 1    | 59000D-36 | Cotter Pins                    | 3.2 x 25       | 2    |
| 59000D-14 | Gear Shaft Sleeve                | #45 C. Steel | 1    | 59000D-37 | Slotted Nuts                   | M14            | 2    |
| 59000D-15 | Carriage Bolt                    | M10 x 30     | 12   | 59000D-38 | Washer                         | D14            | 2    |
| 59000D-16 | Drum Plate Assemb.               |              | 1    | 59000D-39 | Hex Bolt                       | M8 x 40        | 4    |
| 59000D-17 | Drum Leak-Proof Pad              | Rubber       | 1    | 59000D-40 | Tire                           | 14" Rubber     | 2    |
| 59000D-18 | Drum                             | Polyethylene | 1    | 59000D-41 | Axle                           | #45 C. Steel   | 1    |
| 59000D-19 | Gear                             |              | 1    | 59000D-42 | Washer                         | D8             | 4    |
| 59000D-20 | Hex Flange Nut                   | M10 x 30     | 12   | 59000D-43 | Hex Nut                        | M8             | 4    |
| 59000D-21 | Washer                           | #45 C. Steel | 1    | 59000C-44 | Wheelbarrow Support Pipe       |                | 1    |
| 59000D-22 | Driven Shaft Slide Bearing       | Nylon 66     | 2    | 59000C-45 | Lock Washer                    | D8             | 4    |
| 59000D-23 | Grease Fitting                   | M6           | 2    | 59000C-46 | Left Wheelbarrow Frame         |                | 1    |
|           |                                  |              |      | 59000C-47 | On/Off Switch w/Electrical Box |                | 1    |

# Wheelbarrow Cement Mixer Assembly Guide

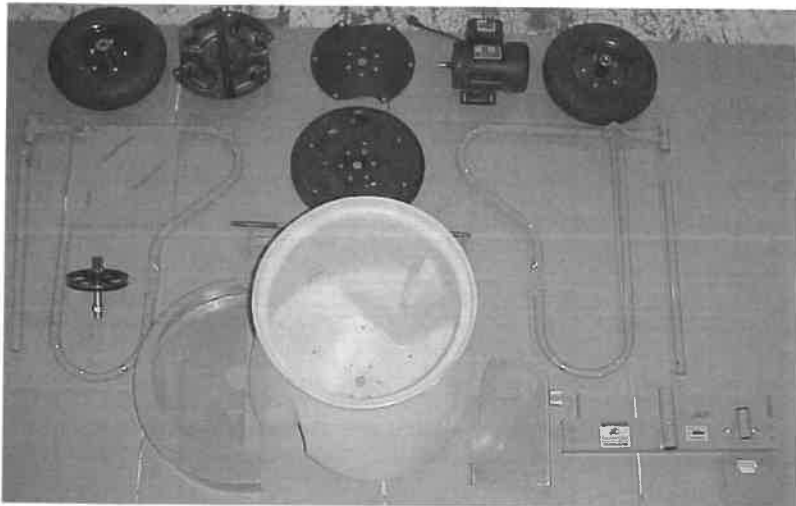

*Components*

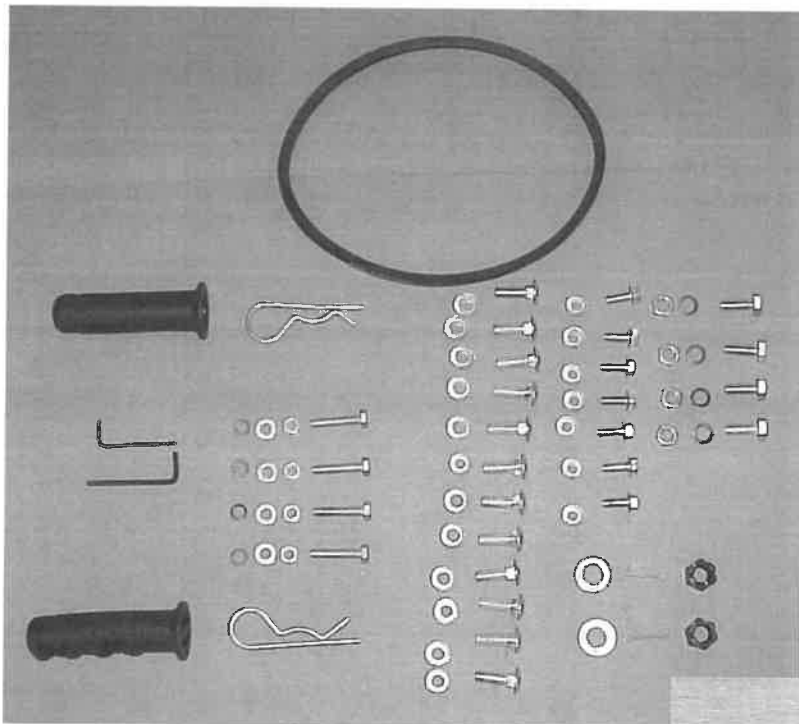

*Standard Parts*

**COMPLETE UNIT  
ASSEMBLED**

**ASSEMBLY GUIDE CONSISTS OF:**

***FRAME ASSEMBLY – 2 PGS.***  
***MOTOR ASSEMBLY – 2 PGS.***  
***DRUM ASSEMBLY – 3 PGS.***



# FRAME ASSEMBLY ...Page 1 of 2

1. Lay out the frame parts.

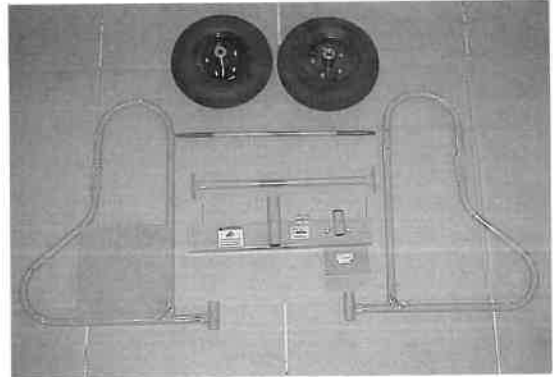

2. Assemble the tires on the axle.  
(# 40 & # 41)

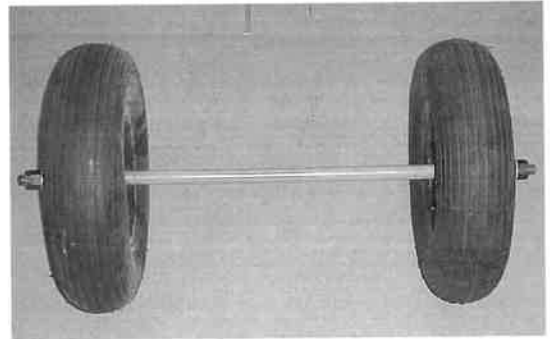

3. Assemble tires and axle to the frame.

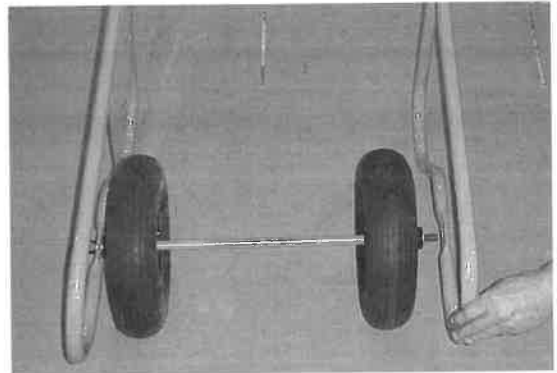

4. Attach the axle to the frame.  
(Using # 36, # 37, and # 38)

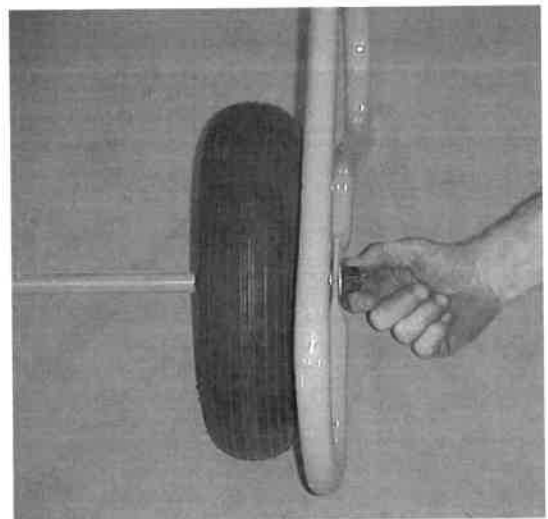

# FRAME ASSEMBLY ...Page 2 of 2

5. Assemble the supporting pipe.  
(Using # 39, # 42, # 43 and # 45)



6. Assemble the drum support frame.  
(Using # 27, # 28, and # 29)

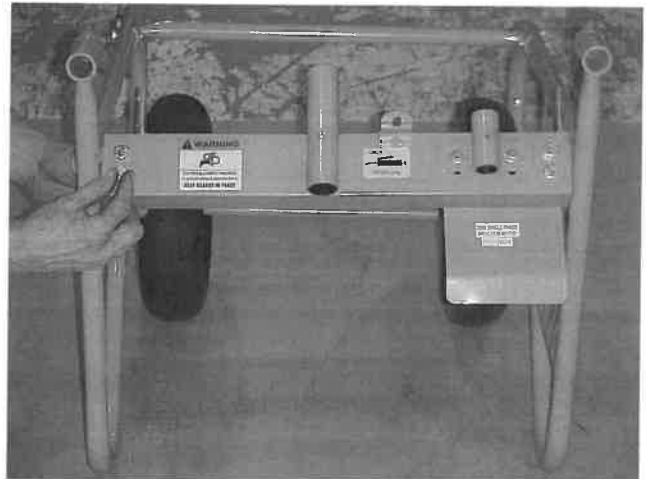

7. Fasten all the bolts and nut.



# MOTOR ASSEMBLY ...Page 1 of 2

1. Assemble the motor onto the frame.  
(Using # 2 and # 3)

NOTE: Assemble the drive pulley (# 30)  
on the motor shaft -  
(If Not Preassembled)

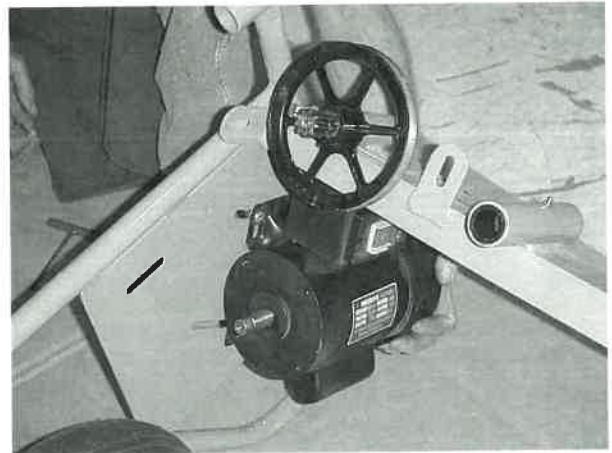

2. Assemble the pinion gear shaft driven pulley to gear sleeve assembly and attach shaft sleeve (# 14).

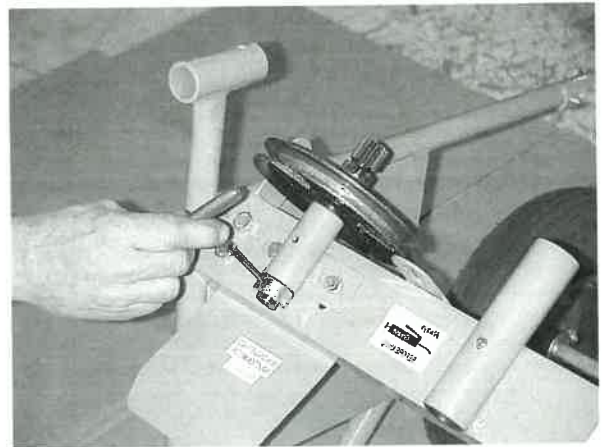

3. Assemble the V-Belt on the pulleys.





# MOTOR ASSEMBLY ....Page 2 of 2

4. Adjust the belt tension and keep pulleys parallel.

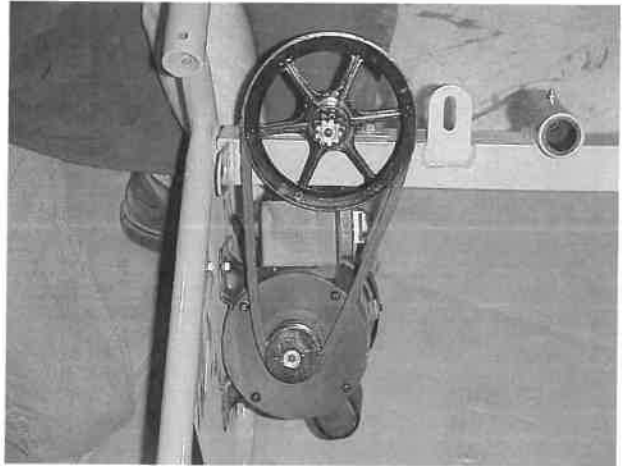

5. Attach the belt guard on the frame.  
(Using # 2 and # 3)

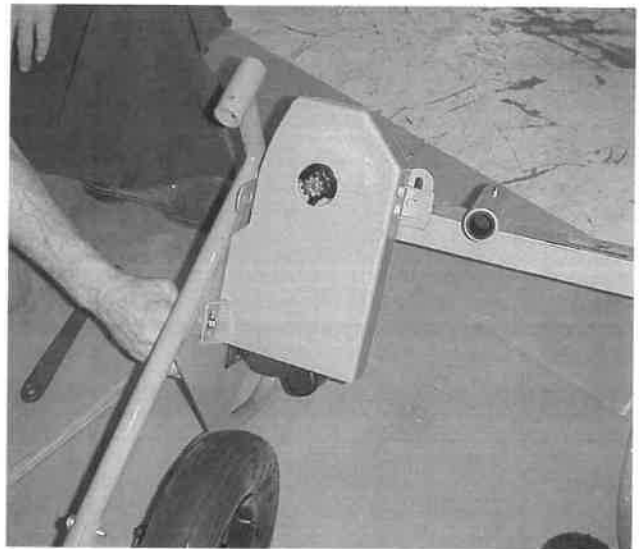

6. Attach the gear guard on the frame.  
(Using # 2 and # 3)

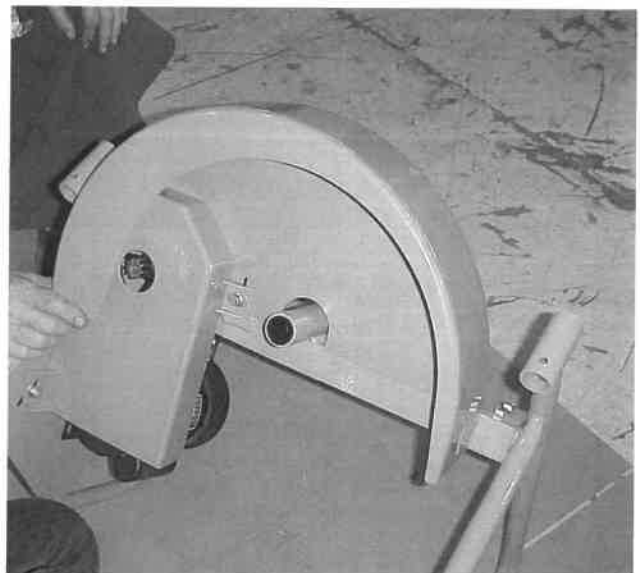

# DRUM ASSEMBLY ... Page 1 of 3

1. Lay out the drum components.

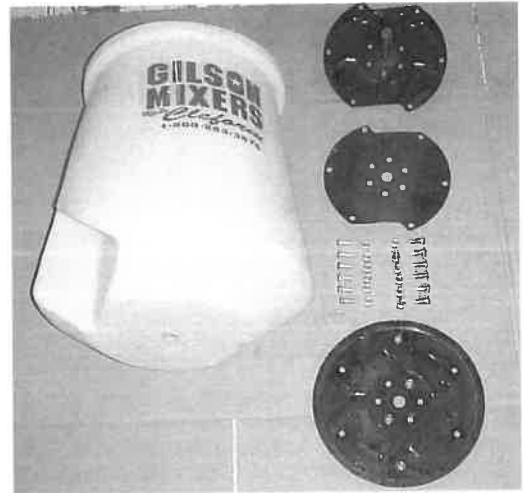

2. Assemble the central paddle (#16) and its Pad (#17) in the drum.



3. Assemble the gear wheel (#19) to bottom of the drum.



4. Bolt the drum plate assembly, pad and gear to drum (Using # 15 and # 20).



## DRUM ASSEMBLY ... Page 2 of 3

5. Put the washer (#21) on the gear shaft.

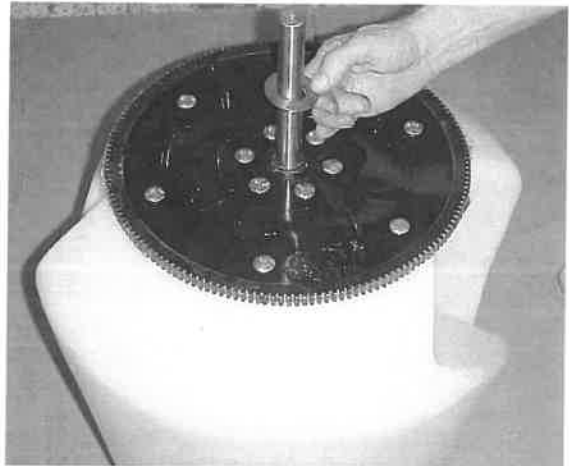

6. Assemble the drum onto the frame.



7. Assemble the shaft positioning sleeve (#26) on the gear shaft.



8. Assemble the handle (#34) on the frame.



5. Set the handle fixing spring clip on the handle.

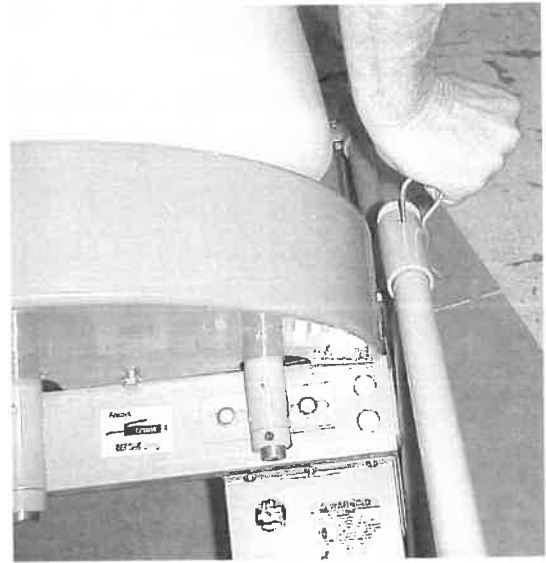

6. Attach the plastic handle cover.

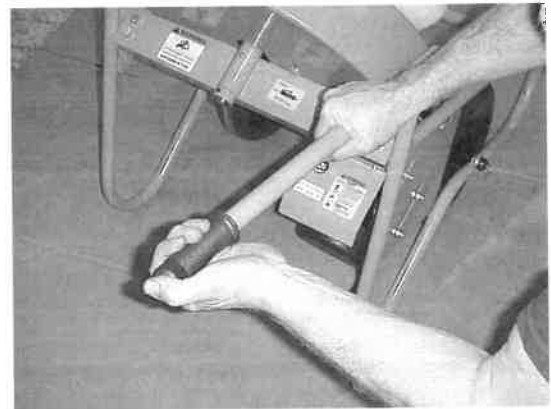

WHEELBARROW MIXER  
FULLY ASSEMBLED



The Power of **RED**



4343 EASTON ROAD  
ST. JOSEPH, MO 64503  
(816) 233-4840 (800) 253-3676  
FAX: (816) 233-4624 (888) 253-3676  
[www.cleform.com](http://www.cleform.com) or [www.gilsonmixer.com](http://www.gilsonmixer.com)  
[sales@cleform.com](mailto:sales@cleform.com)

# GILSON MIXERS

*by Cleform*



GILSON MIXER MODEL 59000D

PARTS MANUAL  
INSTRUCTIONS  
ASSEMBLY GUIDE  
OPERATING INSTRUCTIONS

## WARNING

DO NOT ATTEMPT TO START OR OPERATE  
THIS MIXER UNTIL ALL THE INSTRUCTIONS  
HAVE BEEN READ BY THE  
OPERATOR.

## SAFETY INSTRUCTIONS AND WARNINGS!

If the safety instructions and warnings are not read and carefully followed, personal injury could occur.

### **SAFETY INSTRUCTIONS**

1. Keep hands and clothing away from any moving parts while the mixer is running.
2. Clear the work area around the machine to prevent tripping or falling onto the mixer.
3. Operate on level ground to prevent the mixer from tipping over.
4. Keep all unauthorized and untrained people away from the mixer at all times.
5. DO NOT OPERATE this mixer under the influence of alcohol or while taking medication that impairs your reactions.
6. NEVER run the mixer unattended, turn off the motor when you leave the machine.
7. Do not pull the cord to disconnect it. Keep the cord away from heat, oil, and sharp edges.
8. Use factory authorized parts for replacement.
9. Wear safety glasses when mixer is in use.
10. Never attempt to move the mixer while the motor is on.

### **WARNINGS**

1. Do not operate this mixer until all the warnings and safety instructions have been read and understood by the operator.
2. NEVER operate this mixer without all the guards in place and firmly attached.
3. Make sure that the mixing drum is clear of obstructions and stand clear of the mixer while making power cord connections.
4. Keep all people excluding the operator at least 5 feet away from the mixer during operation.
5. Properly grounded electric circuit is required to protect the operator from possible electric shock.
6. NEVER plug or unplug the motor while standing in or around damp or wet ground.
7. Do not start the motor if the drum is fully loaded.
8. DO NOT OVERLOAD THE MIXER!

### ***LIMITED WARRANTY***

ALL IMPLIED WARRANTIES, INCLUDING THOSE OF MERCHANT ABILITY AND FITNESS FOR A PARTICULAR PURPOSE, ARE LIMITED TO ONE YEAR FROM DATE OF PURCHASE BY THE ORIGINAL RETAIL CUSTOMER AND TO THE EXTENT PERMITTED BY LAW ANY AND ALL IMPLIED WARRANTIES ARE EXCLUDED AND DISCLAIMED AFTER THE EXPIRATION OF SUCH PERIOD.

#### **HOW TO OBTAIN PARTS AND SERVICE INFORMATION:**

For parts and service information, contact either your local dealer or the Cleform Tool Corp. factory:  
CLEFORM TOOL CORP. 4343 Easton Rd. St. Joseph, MO 64503  
PH: (800) 253-3676 FAX: (888) 253-3676 Email: [sales@cleform.com](mailto:sales@cleform.com)

#### **HOW TO ORDER PARTS:**

When ordering parts be sure to indicate the following information:  
Name of each part, complete part number and quantity of each part.

## How to Mix Concrete

Wheelbarrow Mixer

*Model 59000D*

You'll need approximately 1 ¼ gallons of water.

1 – 80 lb. Bag of pre-mix concrete

1. Start Mixer
2. Put in 1 gallon of water
3. Add ½ of 80 lb. Bag of pre-mix concrete – mixture will be very sloppy
4. Slowly add 2<sup>nd</sup> half bag of concrete
5. Add ¼ gallon of water slowly to obtain desired thickness.

## How to mix Sand & Gravel

Wheelbarrow Mixer

59000D

You'll need a square point shovel

Portland cement, gravel or round stone and masonry sand.

1. Start Mixer
2. Put in 1 gallon of water
3. Add 3 shovels full of gravel or round stone
4. Add 1 shovel full of portland cement
5. Add 2 shovels full of masonry sand – slowly
6. Add water to obtain desired thickness

\* Amount of water will vary according to moisture content of sand and gravel.

***Remember to grease fittings before every use!***

